

PSI[©]turn

Reliable internal cooling

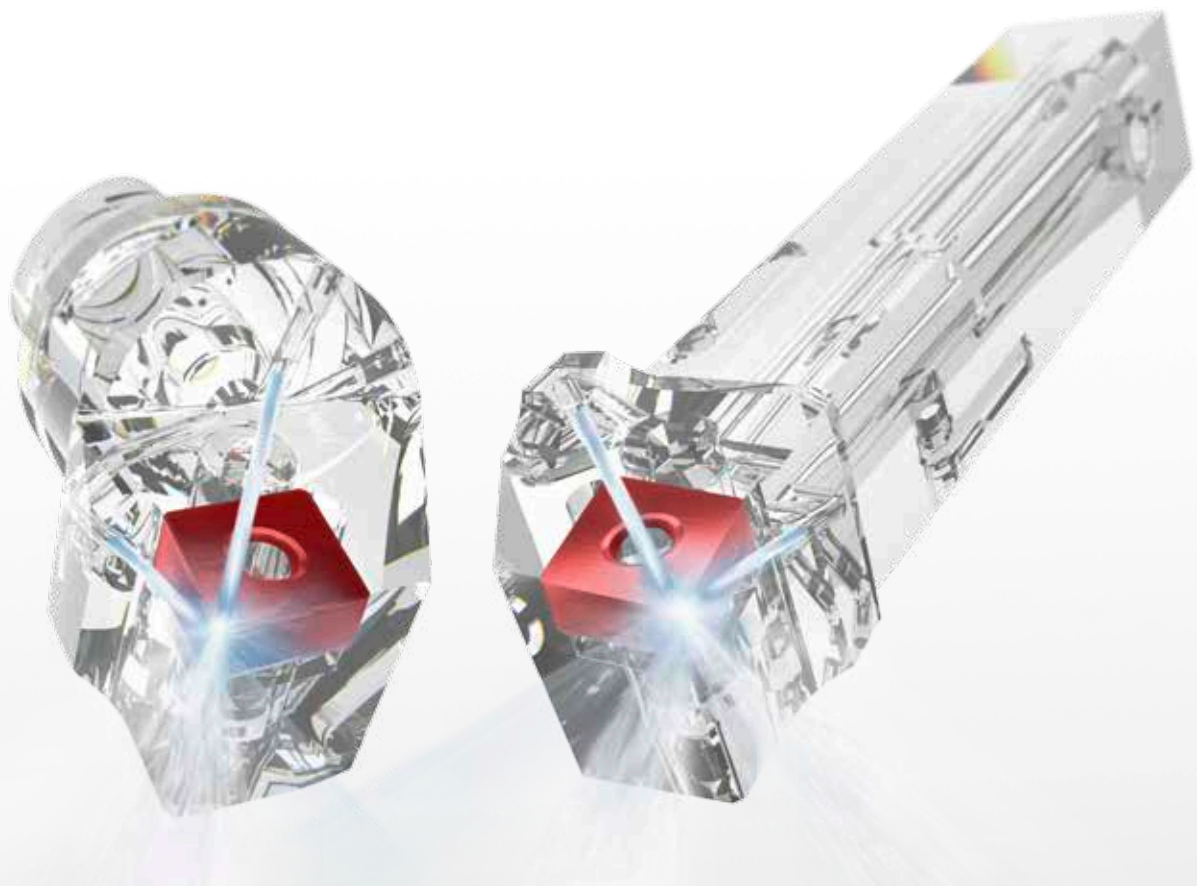



PEOPLE

Cooperate in fair partnership



AMBITION

Question yesterday to provide new solutions for today and tomorrow



SYNERGY

Share our strength

Corporate philosophy

PEOPLE – AMBITION – SYNERGY

These 3 components are the foundation for the success of MAS GmbH.

Trust the experts with more than 40 years of experience in cutting technologies. The specialists with the most modern equipment for the development, design and manufacture of tools. The partners who discover synergies between man and technology and who are able to harness them for your success.

The utmost objective of every project is our customers' and partners' success. Our own success goes hand in hand.

This is and will remain our guide for the future!



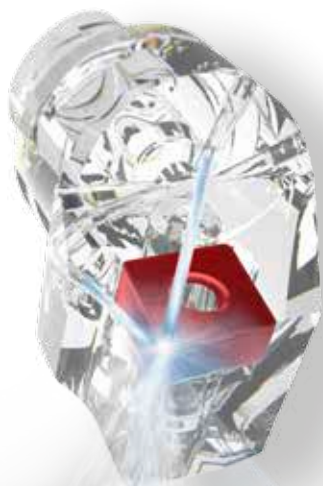

Table of contents

Benefits and features	4
System of order numbers	6
Tool system for sliding lathes:	
Square shanks for positive inserts	7
Square shanks for negative inserts	12
Polygonal shank cone holders for positive inserts	17
Polygonal shank cone holders for negative inserts	19



Benefits and features

- Optimum chip control

- Improvement of tool life

- Reliable internal cooling

- Innovative new design

- Increased productivity

PSI©turn basic holder

Cooling connections

direct IK transfer through
basic holder G $\frac{1}{8}$ from behind

Blind plug HYD-S28 also available
as spare parts

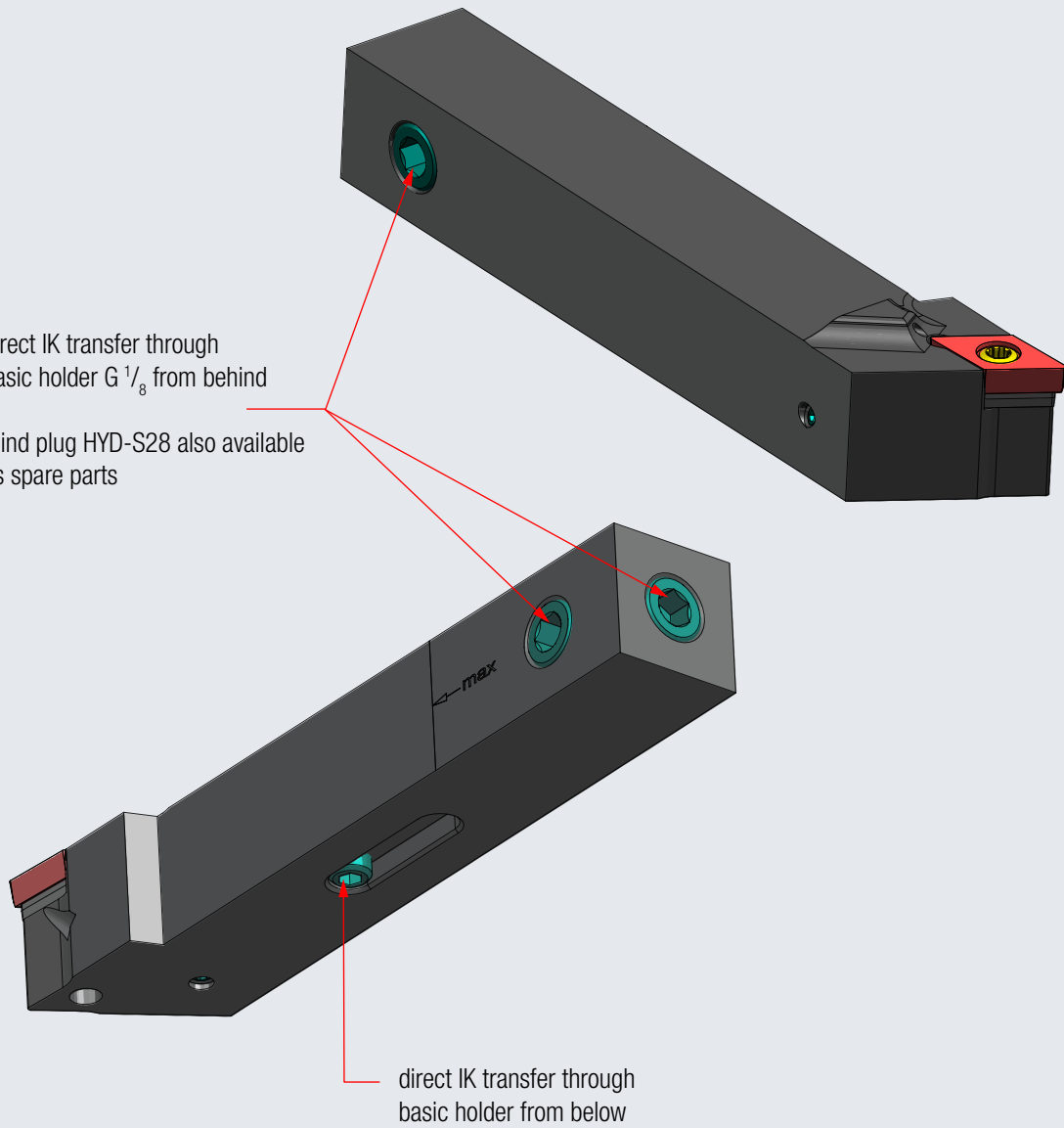

System of order numbers

Square shanks

PSI@turn	1	2	3	4
PSI	2020	SCLCR	09	X

Square shanks designation system

1	Interface:	2020	Square shank 20x20mm
2	Indexable insert angulation	SCLCR	Indexable insert type, clamping, installation position
3	Indexable insert	09	Insert size
4		X	Code for special product

PSK-holders

PSI@turn	1	2	3	4	5
PSI	C3	PDJNR	1745	15	X

PSK-holders designation system

1	Interface	C3	PSK-holder C3
2	Indexable insert angulation	PDJNR	Indexable insert type, clamping, installation position
3	F-dimension; L1:	1745	Dimensions
4	Indexable insert	15	Insert size
5		X	Code for special product

Square shanks for positive inserts

Model SCLCL/R...09

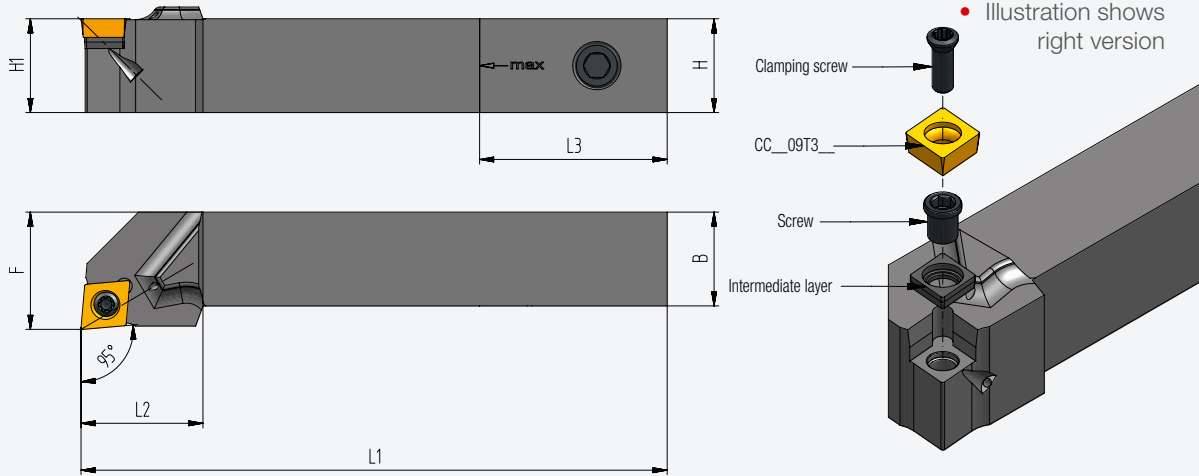

Holders									Spare parts			Indexable insert	
Order no.	Version	H1	H	F	B	L1	L2	L3*	Intermediate layer	Screw	Clamping screw		
PSI-2020-SCLCR09	right	20	20	25	20	125	26	40	●	3609	BCL7/3.5Nm	123511P/3.5Nm	CC...09
PSI-2020-SCLCL09	left	20	20	25	20	125	26	40	●				

* L3= Maximum cut-off length without loss of rear thread

● in stock ○ on request

Model SDJCL/R...07

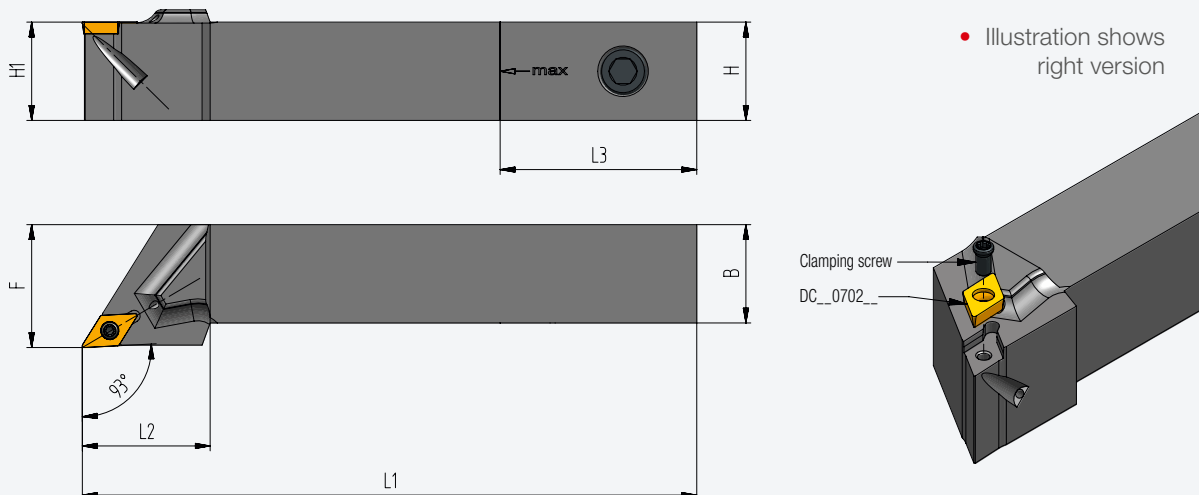

Holders									Spare parts			Indexable insert	
Order no.	Version	H1	H	F	B	L1	L2	L3*	Intermediate layer	Screw	Clamping screw		
PSI-2020-SDJCR07	right	20	20	25	20	125	26	40	●	-	-	BFTX02506N/ 1.5Nm	DC...07
PSI-2020-SDJCL07	left	20	20	25	20	125	26	40	●				

* L3= Maximum cut-off length without loss of rear thread

● in stock ○ on request

Square shanks for positive inserts

Model SDJCL/R...11

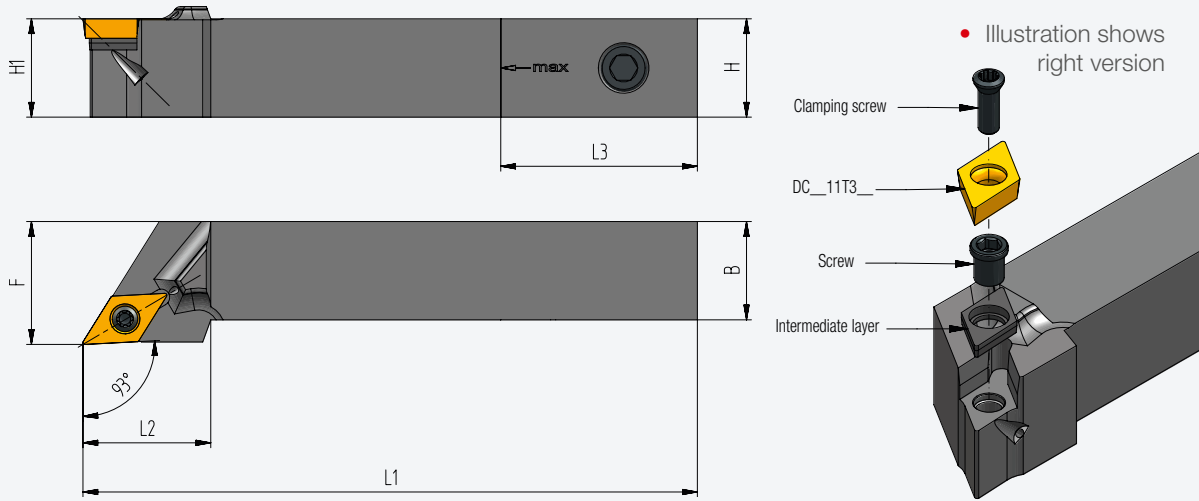

Holders									Spare parts			Indexable insert	
Order no.	Version	H1	H	F	B	L1	L2	L3*	Intermediate layer	Screw	Clamping screw		
PSI-2020-SDJCR11	right	20	20	25	20	125	26	40	●	3711	BCL7/3.5Nm	123511P/3.5Nm	DC...11
PSI-2020-SDJCL11	left	20	20	25	20	125	26	40	●				

* L3= Maximum cut-off length without loss of rear thread

● in stock ○ on request

Model SDHCL/R...11

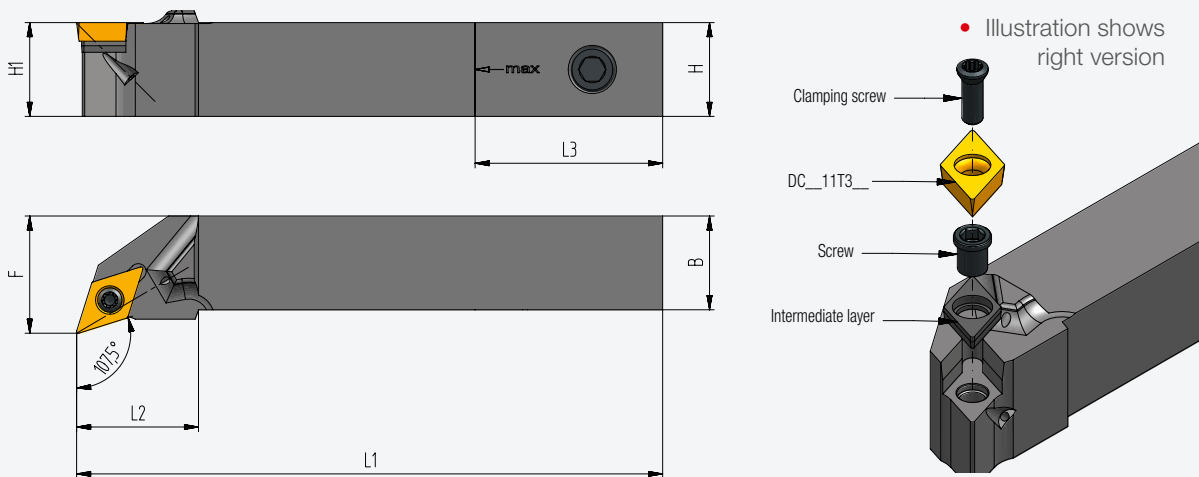

Holders									Spare parts			Indexable insert	
Order no.	Version	H1	H	F	B	L1	L2	L3*	Intermediate layer	Screw	Clamping screw		
PSI-2020-SDHCR11	right	20	20	25	20	125	26	40	●	3711	BCL7/3.5Nm	123511P/3.5Nm	DC...11
PSI-2020-SDHCL11	left	20	20	25	20	125	26	40	●				

* L3= Maximum cut-off length without loss of rear thread

● in stock ○ on request

Square shanks for positive inserts

Model SDUCL/R...11

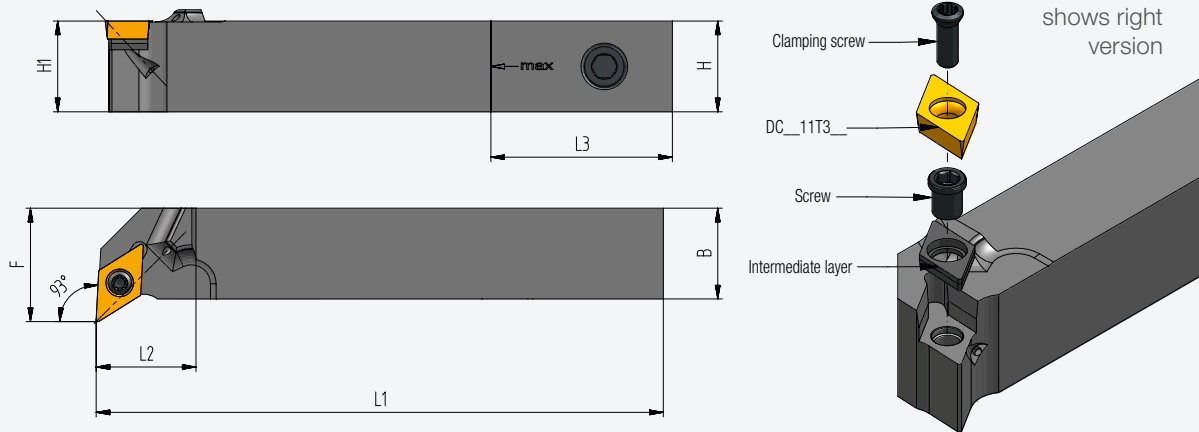

Holders									Spare parts			Indexable insert	
Order no.	Version	H1	H	F	B	L1	L2	L3*	Inter-mediate layer	Screw	Clamping screw		
PSI-2020-SDUCR11	right	20	20	25	20	125	22	40	○	3711	BCL7/3.5Nm	123511P/3.5Nm	DC...11
PSI-2020-SDUCL11	left	20	20	25	20	125	22	40	○				

* L3= Maximum cut-off length without loss of rear thread

● in stock ○ on request

Model SVJCL/R...11

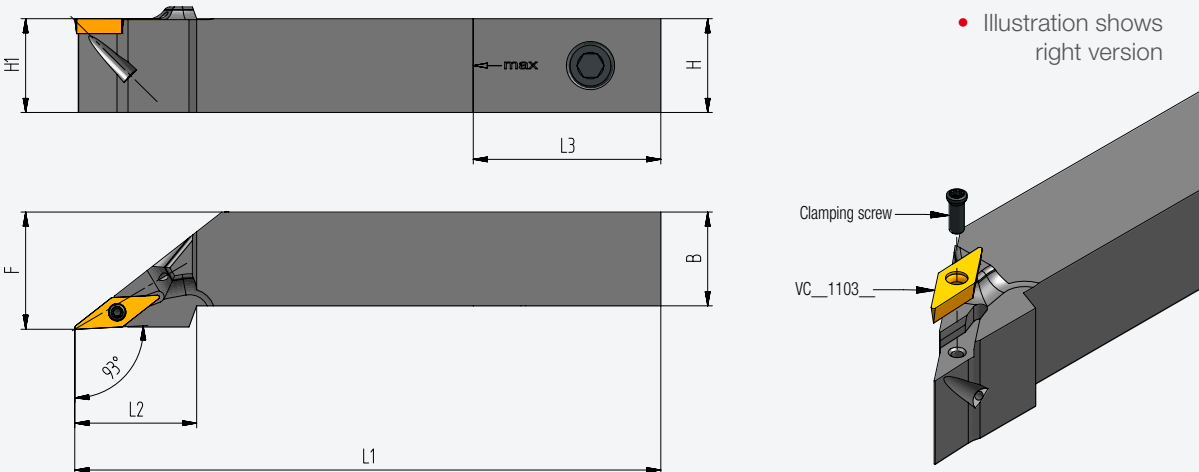

Holders									Spare parts			Indexable insert	
Order no.	Version	H1	H	F	B	L1	L2	L3*	Inter-mediate layer	Screw	Clamping screw		
PSI-2020-SVJCR11	right	20	20	25	20	125	26	40	○	-	-	BFTX02508 NV 1.5Nm	CC...09
PSI-2020-SVJCL11	left	20	20	25	20	125	26	40	○				

* L3= Maximum cut-off length without loss of rear thread

● in stock ○ on request

Square shanks for positive inserts

Model SVJBL/R...16

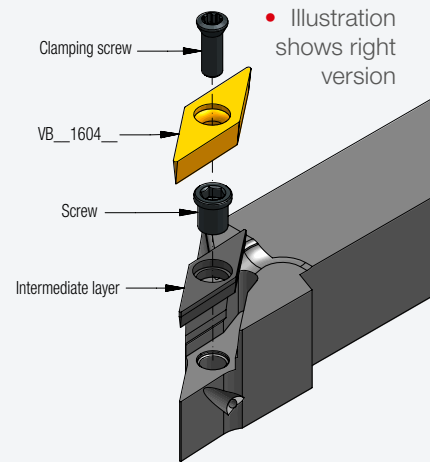
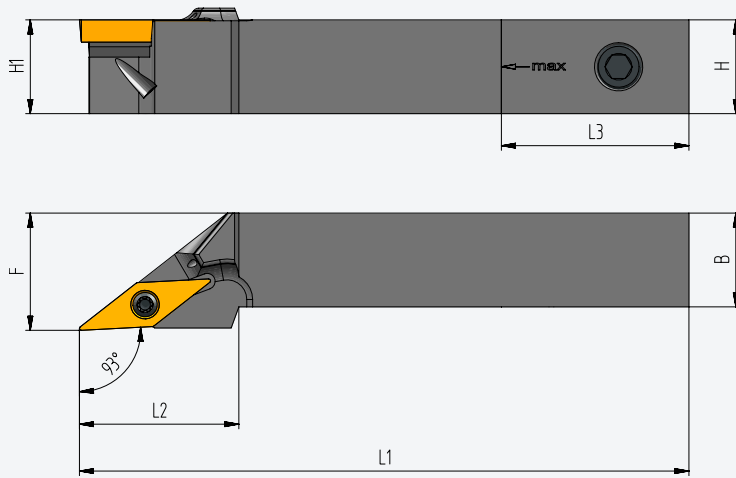

Holders									Spare parts			Indexable insert	
Order no.	Version	H1	H	F	B	L1	L2	L3*	Intermediate layer	Screw	Clamping screw		
PSI-2020-SVJBR16	right	20	20	25	20	125	34	40	○	3716	BLC7/3.5Nm	123511P/3.5Nm	VB...16
PSI-2020-SVJBL16	left	20	20	25	20	125	34	40	○				

* L3= Maximum cut-off length without loss of rear thread

● in stock ○ on request

Model SVPBL/R...16

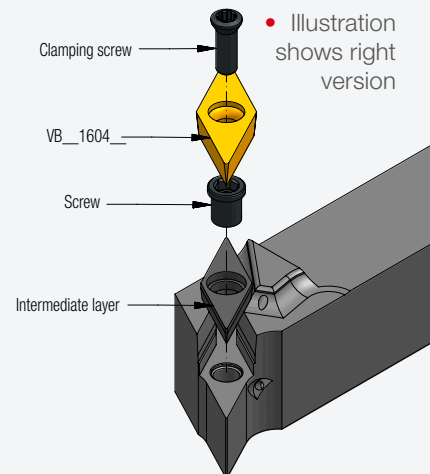
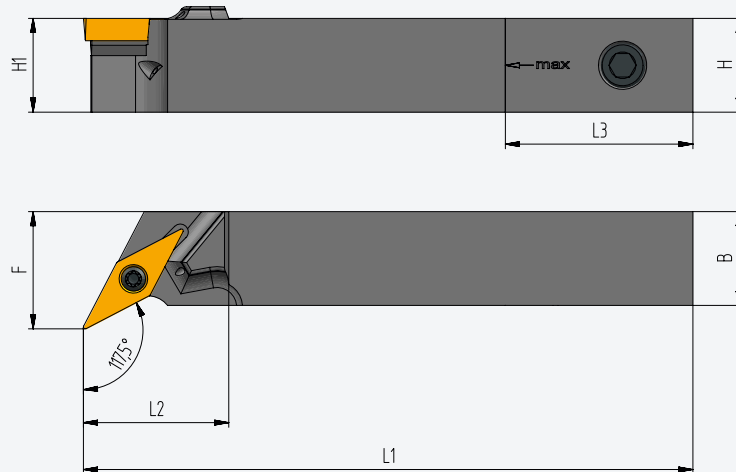

Holders									Spare parts			Indexable insert	
Order no.	Version	H1	H	F	B	L1	L2	L3*	Intermediate layer	Screw	Clamping screw		
PSI-2020-SVPBR16	right	20	20	25	20	125	31	40	○	3716	BLC7/3.5Nm	123511P/3.5Nm	VB...16
PSI-2020-SVPBL16	left	20	20	25	20	125	31	40	○				

* L3= Maximum cut-off length without loss of rear thread

● in stock ○ on request

Square shanks for positive inserts

Model SVVBL/R...16

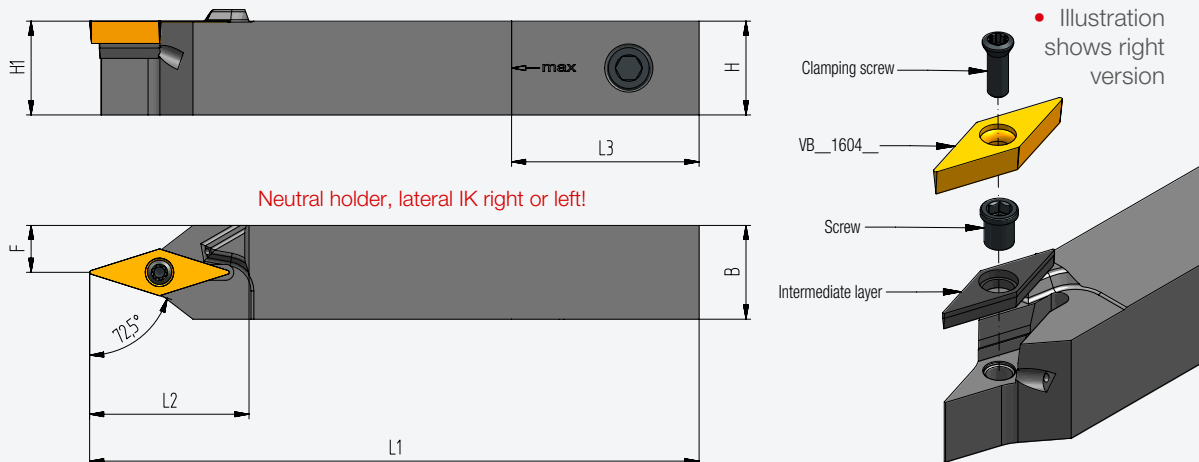

Holders									Spare parts			Indexable insert	
Order no.	Version	H1	H	F	B	L1	L2	I3*	Inter-mediate layer	Screw	Clamping screw		
PSI-2020-SVBR16	right	20	20	25	20	125	34	40	○	3711	BLC7/3.5Nm	123511P/3.5Nm	VB...16
PSI-2020-SVVBL16	left	20	20	25	20	125	34	40	○				

* L3= Maximum cut-off length without loss of rear thread

● in stock ○ on request

Square shanks for negative inserts

Model PCLNL/R...12

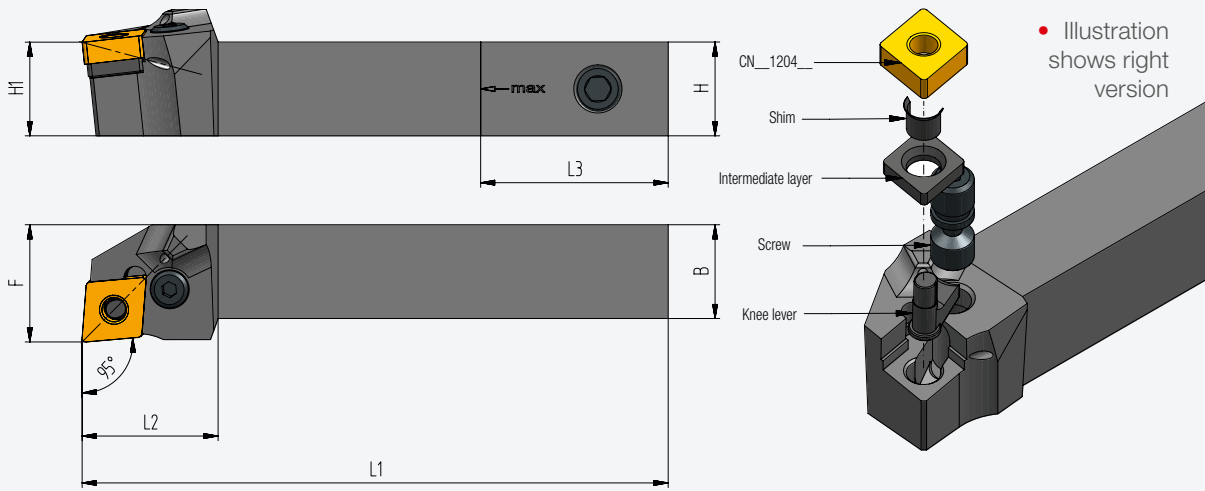

Holders									Spare parts				Indexable insert	
Order no.	Version	H1	H	F	B	L1	L2	L3*	Knee lever	Screw	Intermediate layer	Shim		
PSI-2020-PCLNR12	right	20	20	25	20	125	29	40	●	8012	1608/4Nm	3612	4112	CN...12
PSI-2020-PCLNL12	left	20	20	25	20	125	29	40	●					

* L3= Maximum cut-off length without loss of rear thread

● in stock ○ on request

Model PCLNL/R...16

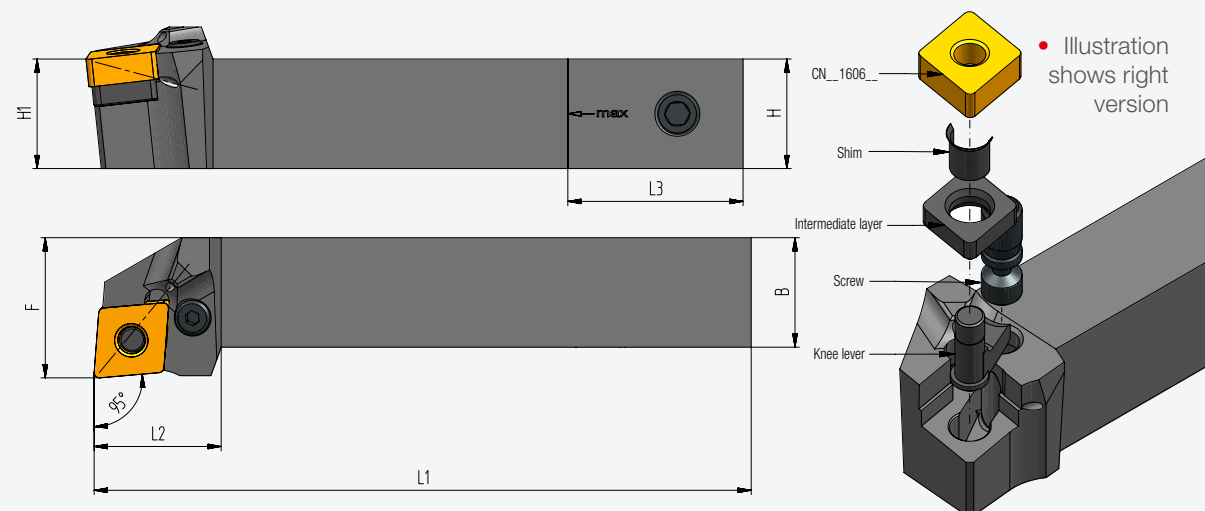

Holders										Spare parts				Indexable insert
Order no.	Version	H1	H	F	B	L1	L2	L3*		Knee lever	Screw	Intermediate layer	Shim	
PSI-2020-PCLNR16	right	20	20	25	20	125	33.5	40	○	438.3-831	438.3-831 5Nm	171.31-852	174.3-864	CN...16
PSI-2020-PCLNL16	left	20	20	25	20	125	33.5	40	○					

* L3= Maximum cut-off length without loss of rear thread

● in stock ○ on request

Square shanks for negative inserts

Model PDJNL/R...11

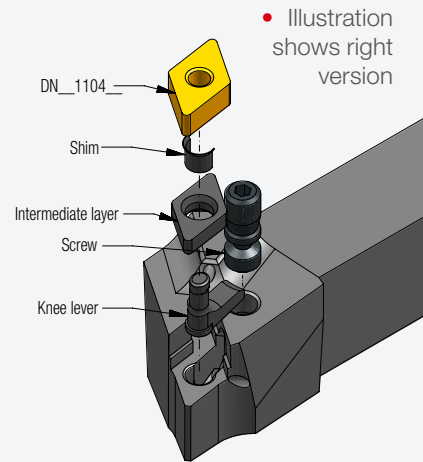
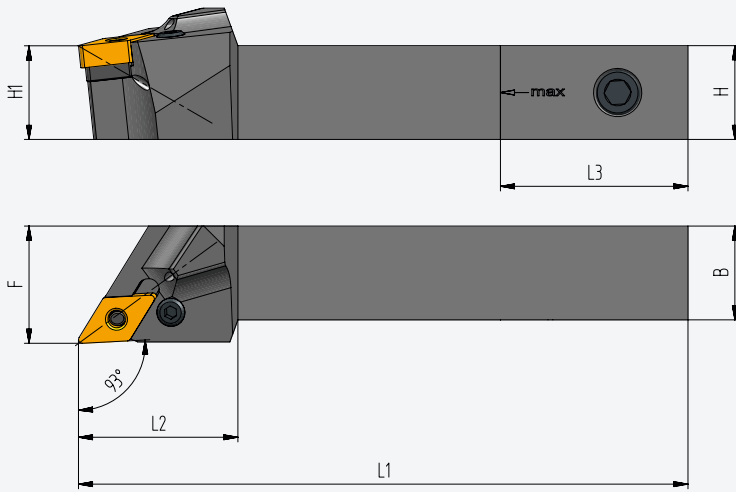

Holders									Spare parts				Indexable insert	
Order no.	Version	H1	H	F	B	L1	L2	L3*	Knee lever	Screw	Intermediate layer	Shim		
PSI-2020-PDJNR11	right	20	20	25	20	130	34	40	●	8411	1608/3.5Nm	3710	4108	DN...11
PSI-2020-PDJNL11	left	20	20	25	20	130	34	40	●					

* L3= Maximum cut-off length without loss of rear thread

● in stock ○ on request

Model PDHNL/R...11

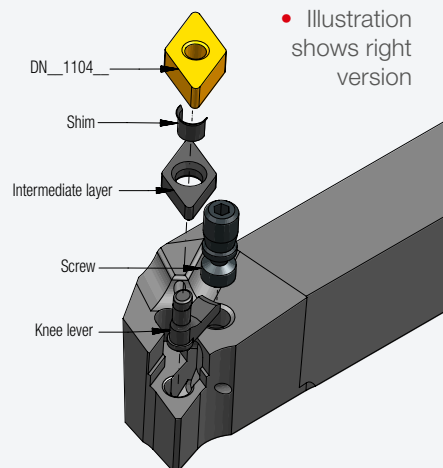
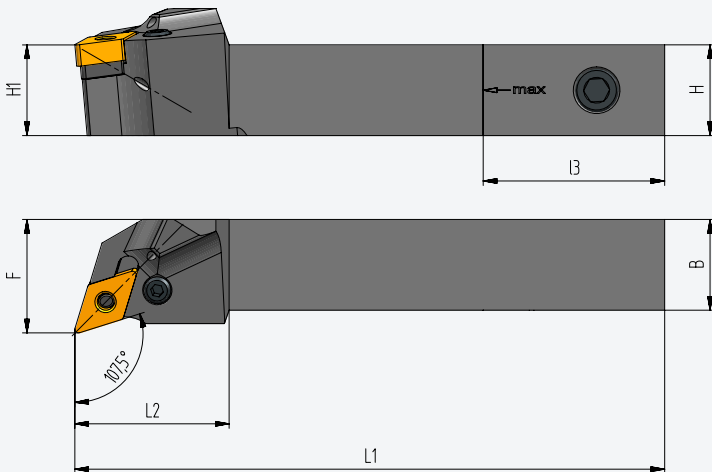

Holders									Spare parts				Indexable insert	
Order no.	Version	H1	H	F	B	L1	L2	L3*	Knee lever	Screw	Intermediate layer	Shim		
PSI-2020-PDHNR11	right	20	20	25	20	125	34	40	○	8411	1606/3.5Nm	3710	4108	DN...11
PSI-2020-PDHNL11	left	20	20	25	20	125	34	40	○					

* L3= Maximum cut-off length without loss of rear thread

● in stock ○ on request

Square shanks for negative inserts

Model PDJNL/R...15

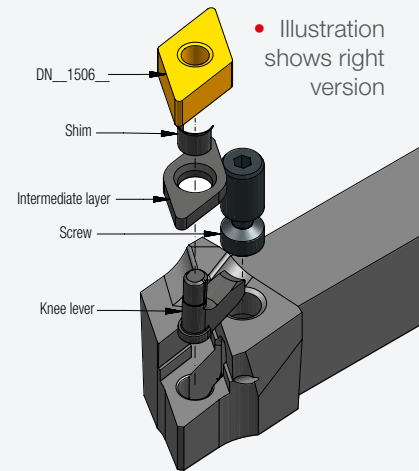
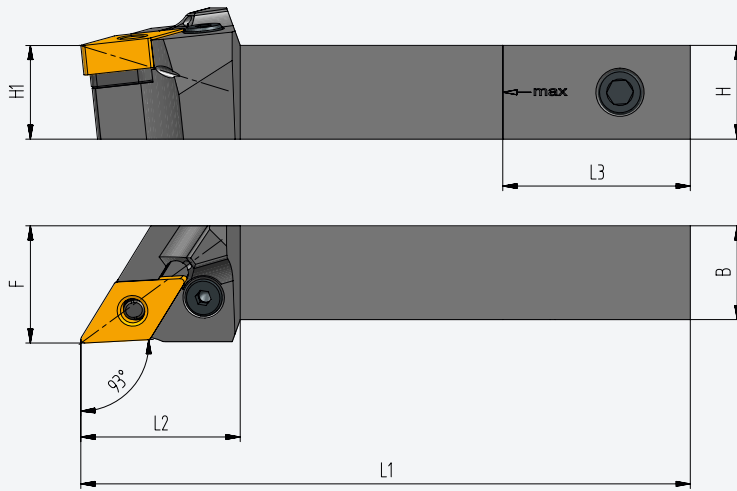

Holders									Spare parts				Indexable insert	
Order no.	Version	H1	H	F	B	L1	L2	L3*	Knee lever	Screw	Intermediate layer	Shim		
PSI-2020-PDJNR15	right	20	20	25	20	130	34	40	●	8415	1638/4Nm	3715	4112	DN...15
PSI-2020-PDJNL15	left	20	20	25	20	130	34	40	●					

* L3= Maximum cut-off length without loss of rear thread

● in stock ○ on request

Model PVVNL/R...16

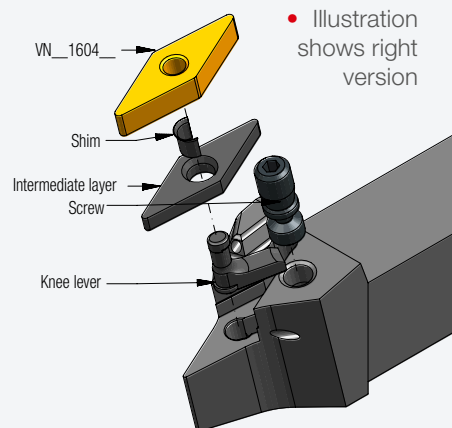
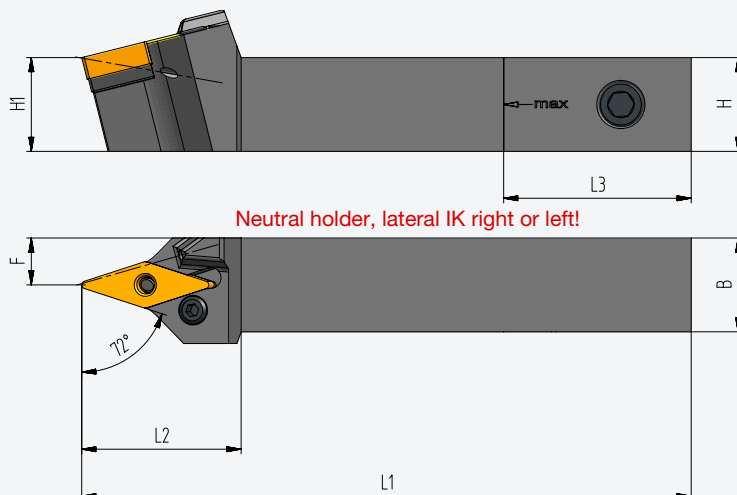

Holders									Spare parts				Indexable insert	
Order no.	Version	H1	H	F	B	L1	L2	L3*	Knee lever	Screw	Intermediate layer	Shim		
PSI-2020-PVVNR16	right	20	20	25	20	125	34	40	○	8411	1606/3.5Nm	5322256-01	4108	VN...16
PSI-2020-PVVNL16	left	20	20	25	20	125	34	40	○					

* L3= Maximum cut-off length without loss of rear thread

● in stock ○ on request

Square shanks for negative inserts

Model PVJNL/R...16

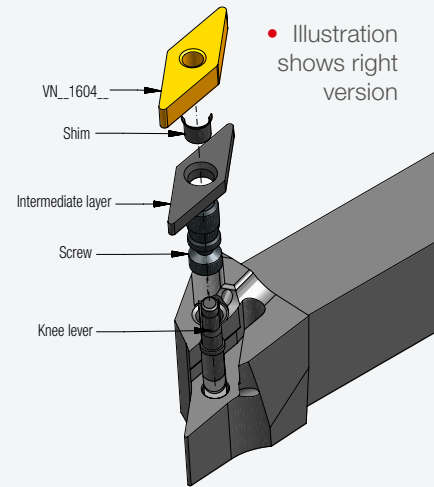
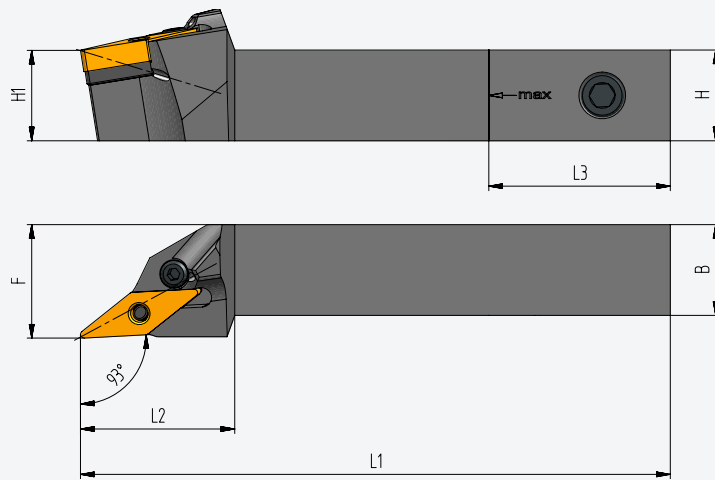

Holders									Spare parts				Indexable insert	
Order no.	Version	H1	H	F	B	L1	L2	L3*	Knee lever	Screw	Inter-mediate layer	Shim		
PSI-2020-PVJNR16	right	20	20	25	20	125	34	40	○	8411	1606/3.5Nm	5322256-01	4108	VN...16
PSI-2020-PVJNL16	left	20	20	25	20	125	34	40	○					

* L3= Maximum cut-off length without loss of rear thread

● in stock ○ on request

Model PWJNL/R...08

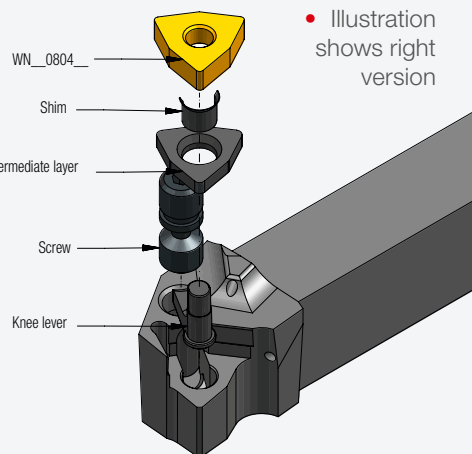
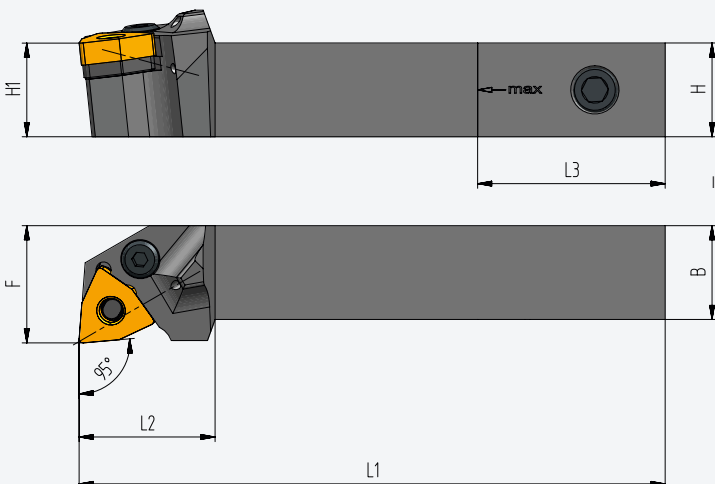

Holders									Spare parts				Indexable insert	
Order no.	Version	H1	H	F	B	L1	L2	L3*	Knee lever	Screw	Inter-mediate layer	Shim		
PSI-2020-PWJNR08	right	20	20	25	20	125	29	40	○	8412	1608/5Nm	3308M	4112	WN...08
PSI-2020-PWJNL08	left	20	20	25	20	125	29	40	○					

* L3= Maximum cut-off length without loss of rear thread

● in stock ○ on request

NOTES

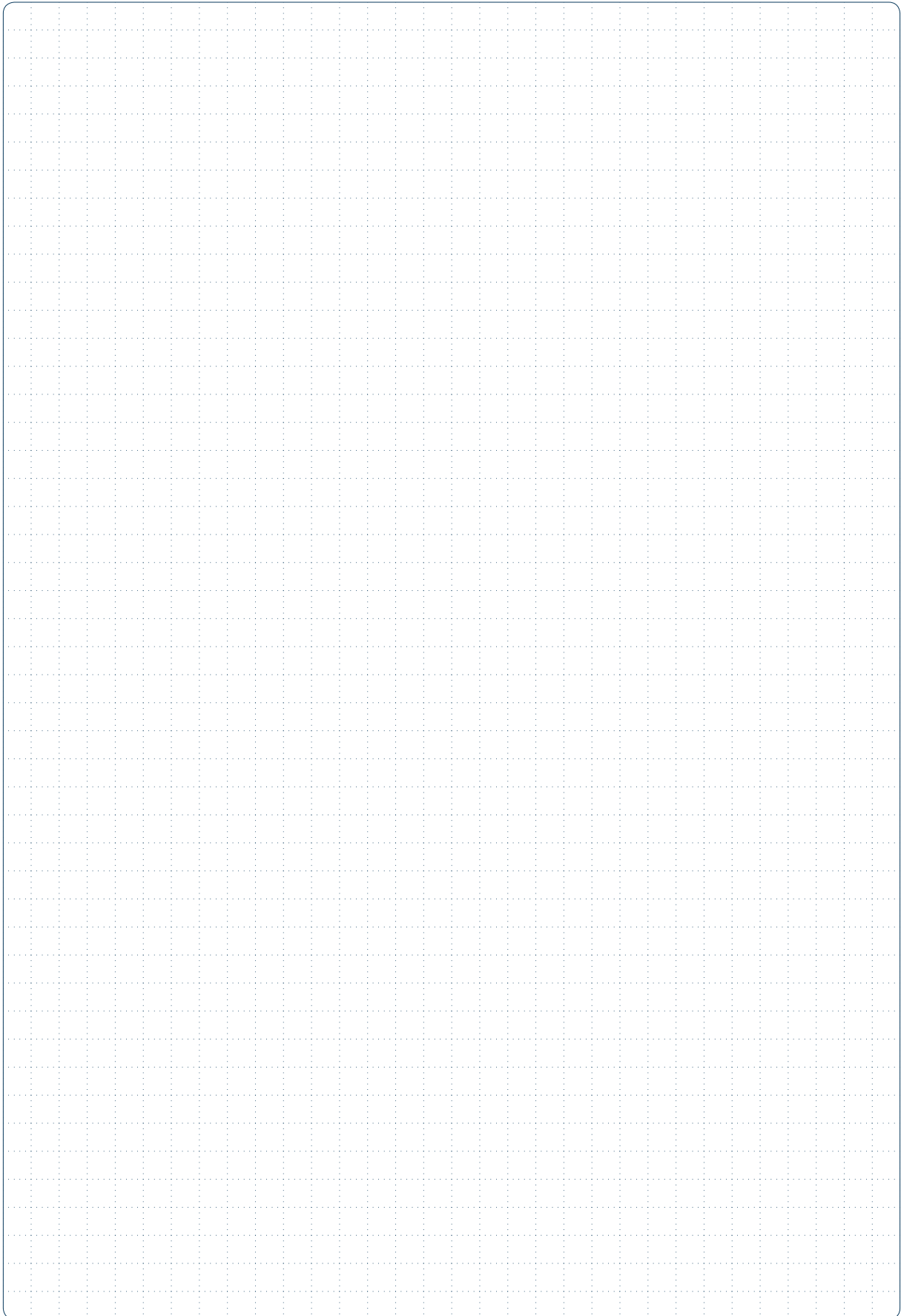

PSK holders for positive inserts

Model SDJCL/R...07

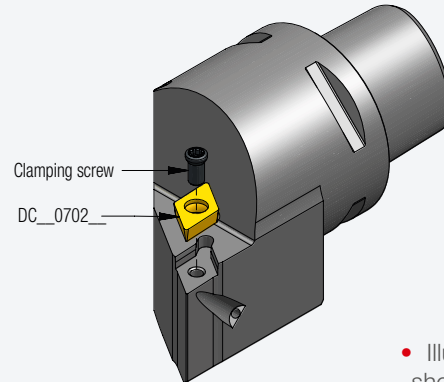
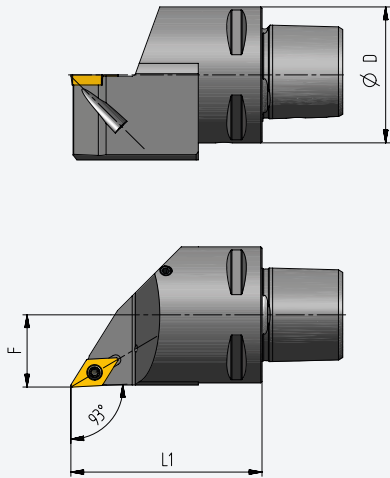

• Illustration shows right version

Holders					Spare parts				Indexable insert	
Order no.	Version	D	L1	F	Knee lever	Screw	Clamping screw	Shim		
PSI-C3-SDJCR-1745-07	right	32	45	17	●	-	-	BFTX02506N/1.5Nm	4112	DC...07
PSI-C3-SDJCL-1745-07	left	32	45	17	●	-	-	BFTX02506N/1.5Nm	4112	DC...07

● in stock ○ on request

Model SDHCL/R...07

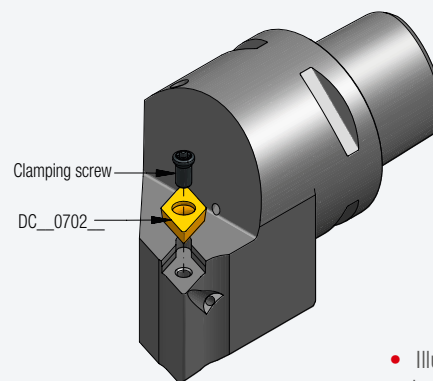
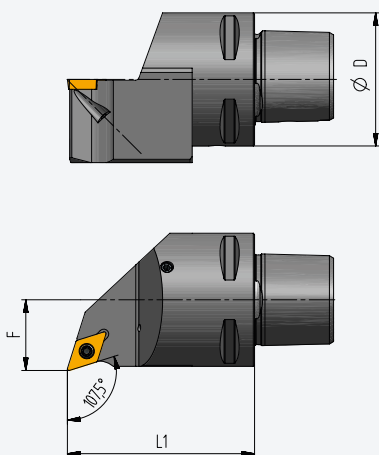

• Illustration shows right version

Holders					Spare parts				Indexable insert	
Order no.	Version	D	L1	F	Knee lever	Screw	Clamping screw	Shim		
PSI-C3-SDHCR-1745-07	right	32	45	17	●	-	-	BFTX02506N/1.5Nm	4112	DC...07
PSI-C3-SDHCL-1745-07	left	32	45	17	●	-	-	BFTX02506N/1.5Nm	4112	DC...07

● in stock ○ on request

PSK holders for positive inserts

Model SDJCL/R...11

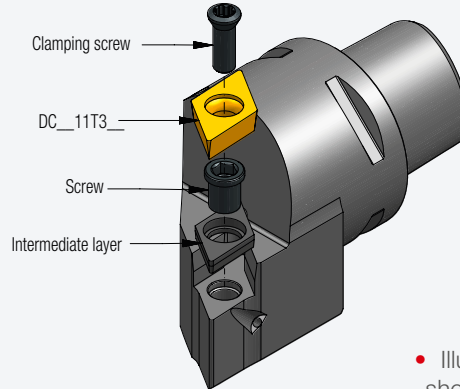
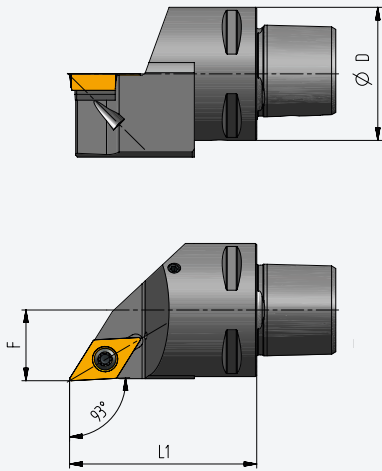

• Illustration shows right version

Holders					Spare parts				Indexable insert	
Order no.	Version	D	L1	F	Intermediate layer	Screw	Clamping screw	Shim		
PSI-C3-SDJCR-1745-11	right	32	45	17	●	3711	BLC7/3.5Nm	123511P	-	DC...11
PSI-C3-SDJCL-1745-11	left	32	45	17	●					

● in stock ○ on request

Model SDHCL/R...11

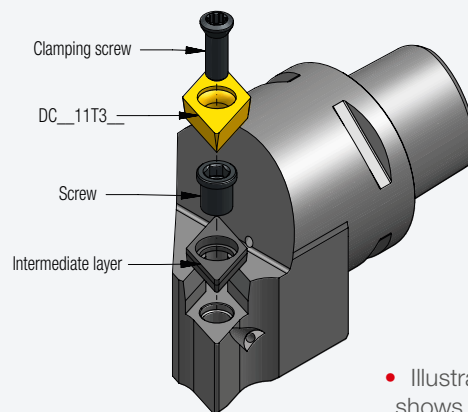
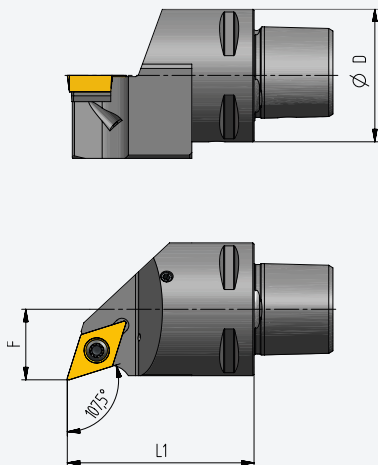

• Illustration shows right version

Holders					Spare parts				Indexable insert	
Order no.	Version	D	L1	F	Intermediate layer	Screw	Clamping screw	Shim		
PSI-C3-SDHCR-1745-11	right	32	45	17	●	3711	BLC7/3.5Nm	123511P	-	DC...11
PSI-C3-SDHCL-1745-11	left	32	45	17	●					

● in stock ○ on request

PSK holders for positive inserts

Model SCLCL/R...09

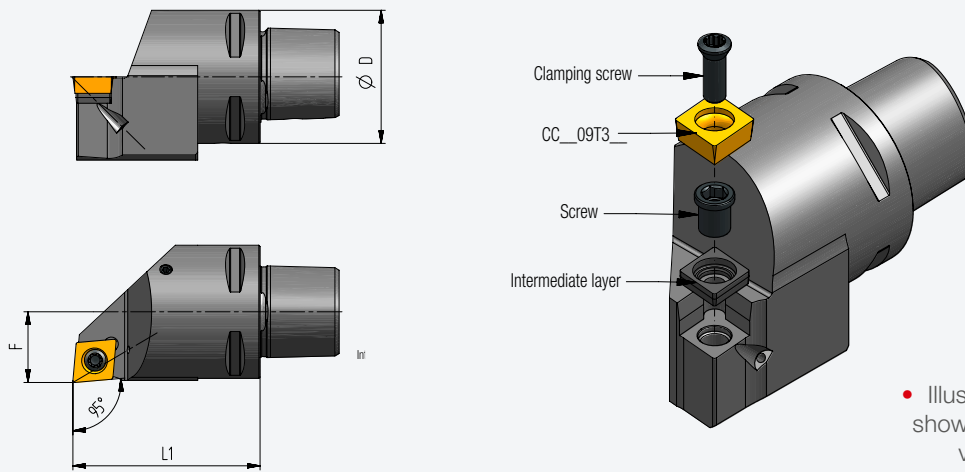

Holders					Spare parts				Indexable insert	
Order no.	Version	D	L1	F	Inter-mediate layer	Screw	Clamping screw	Shim		
PSI-C3-SCLCR-1745-09	right	32	45	17	●	3609	BLC7/3.5Nm	123511P	-	CC...09
PSI-C3-SCLCL-1745-09	left	32	45	17	●					

● in stock ○ on request

PSK holders for negative inserts

Model PCLNL/R...12

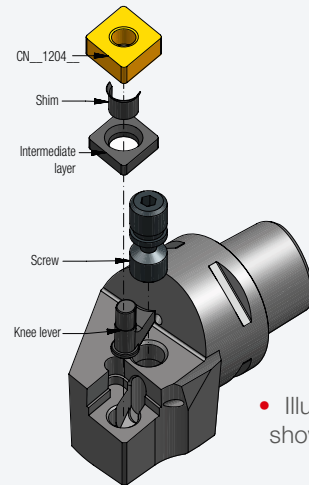
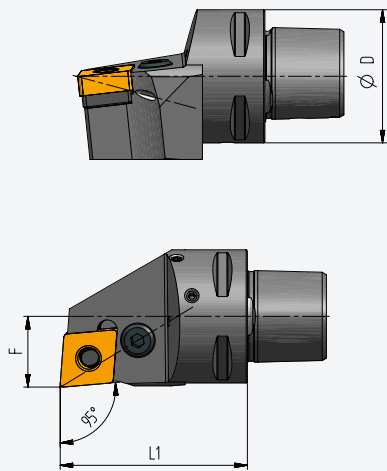

• Illustration shows right version

Holders					Spare parts				Indexable insert	
Order no.	Version	D	L1	F	Knee lever	Screw	Intermediate layer	Shim		
PSI-C3-PCLNR-1745-12	right	32	45	17	●	8012	1608/4Nm	3612M	4112	CN...12
PSI-C3-PCLNL-1745-12	left	32	45	17	●					

● in stock ○ on request

Model PCLNL/R...16

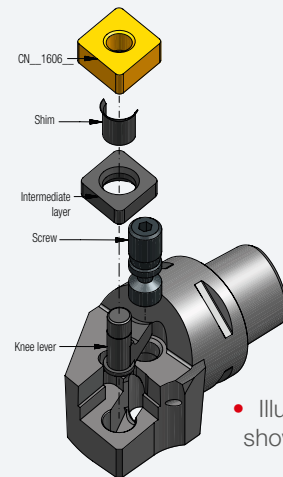
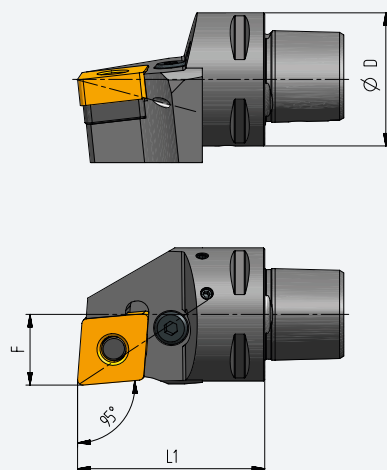

• Illustration shows right version

Holders					Spare parts				Indexable insert	
Order no.	Version	D	L1	F	Knee lever	Screw	Intermediate layer	Shim		
PSI-C3-PCLNR-1745-16	right	32	45	17	●	8012	1608/4Nm	3616M	4115	CN...16
PSI-C3-PCLNL-1745-16	left	32	45	17	●					

● in stock ○ on request

PSK holders for negative inserts

Model PDJNL/R...11

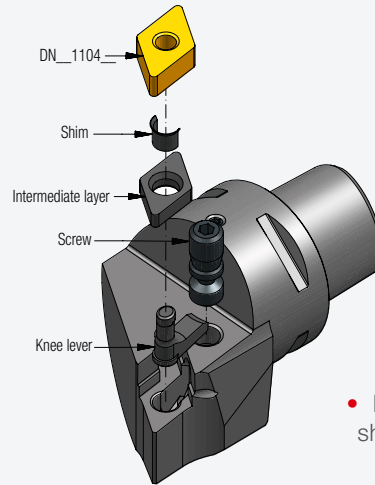
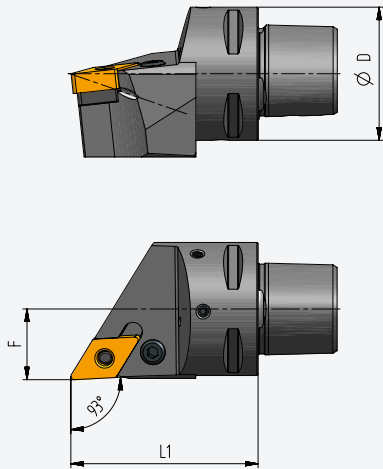

• Illustration shows right version

Holders					Spare parts				Indexable insert	
Order no.	Version	D	L1	F	Knee lever	Screw	Intermediate layer	Shim		
PSI-C3-PDJNR-1745-11	right	32	45	17	●	8411	1606/3.5Nm	3710M	4108	DN...11
PSI-C3-PDJNL-1745-11	left	32	45	17	●					

● in stock ○ on request

Model PDJNL/R...15

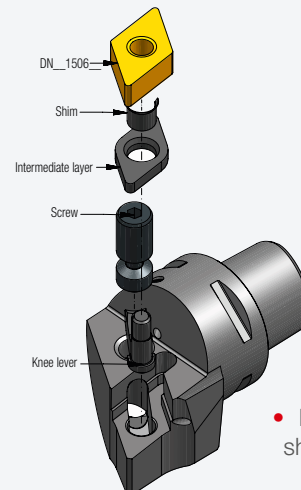
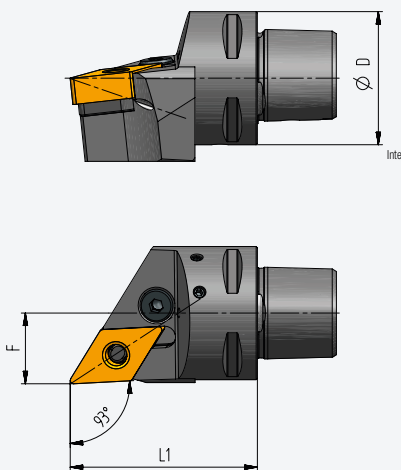

• Illustration shows right version

Holders					Spare parts				Indexable insert	
Order no.	Version	D	L1	F	Knee lever	Screw	Intermediate layer	Shim		
PSI-C3-PDJNR-1745-15	right	32	45	17	●	8415	1638/4Nm	3715M	4112	DN...15
PSI-C3-PDJNL-1745-15	left	32	45	17	●					

● in stock ○ on request

PSK holders for negative inserts

Model PVJNL/R...16

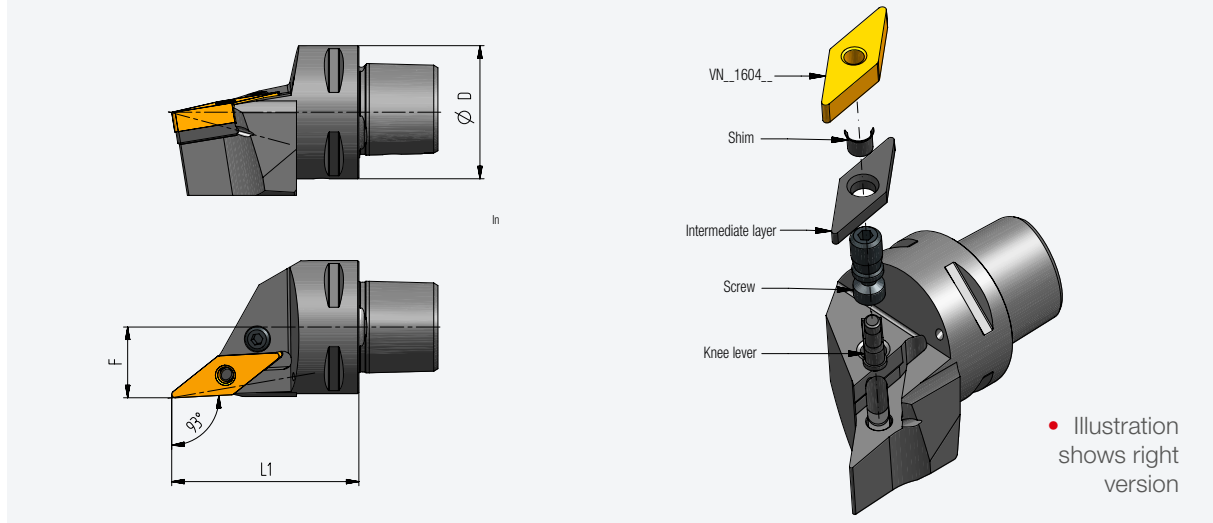

Holders					Spare parts				Indexable insert	
Order no.	Version	D	L1	F	Knee lever	Screw	Intermediate layer	Shim		
PSI-C3-PVJNR-1745-16	right	32	45	17	●	8411	1606/3.5Nm	5322256-01	4108	VN...16
PSI-C3-PVJNL-1745-16	left	32	45	17	●					

● in stock ○ on request

Model PWLNL/R...08

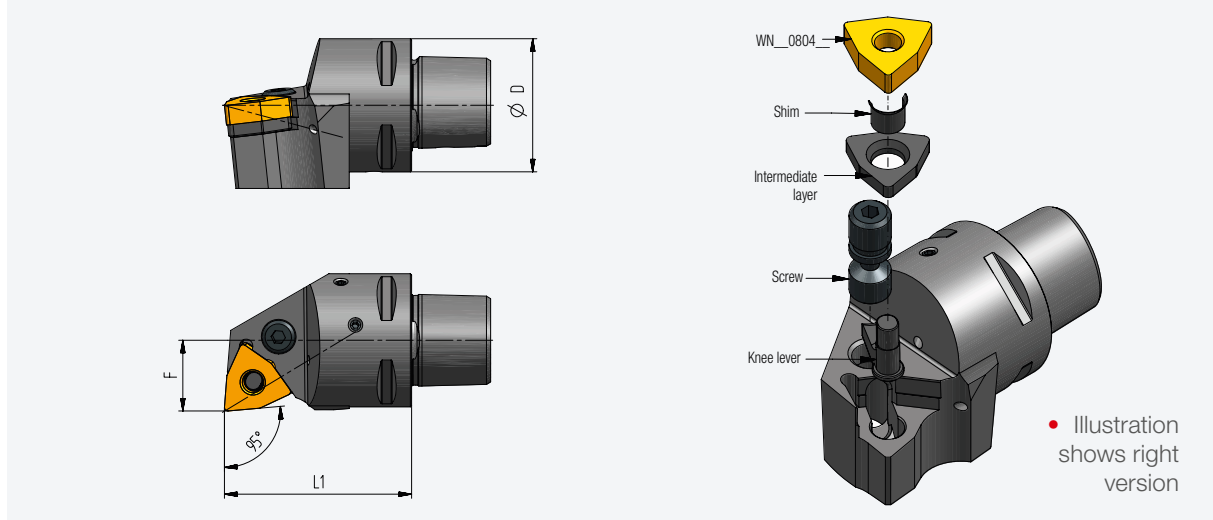

Holders					Spare parts				Indexable insert	
Order no.	Version	D	L1	F	Knee lever	Screw	Intermediate layer	Shim		
PSI-C3-PWLNLR-1745-08	right	32	45	17	●	8012	1608/4Nm	3608M	4112	WN...08
PSI-C3-PWLNL-1745-08	left	32	45	17	●					

● in stock ○ on request

NOTES

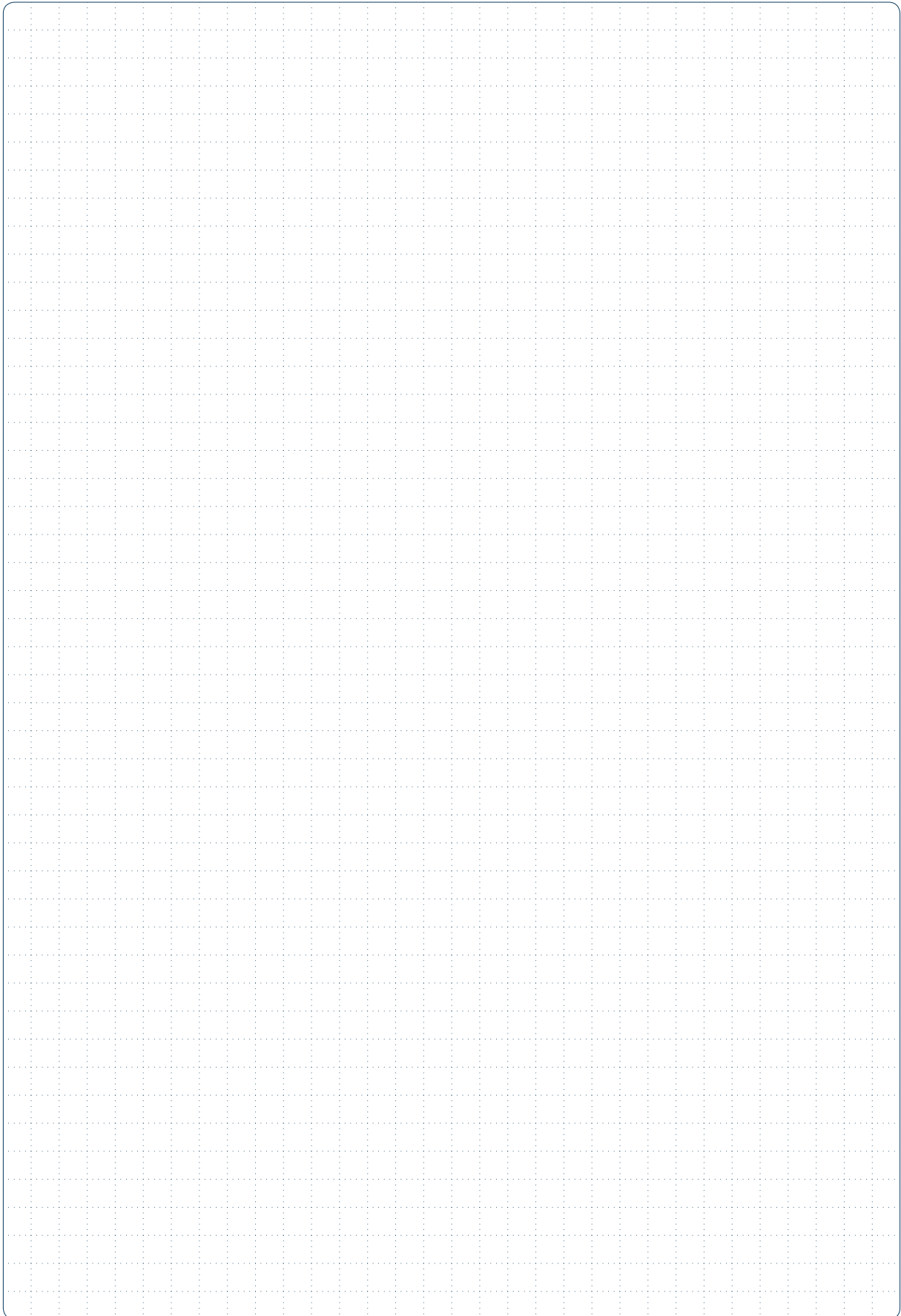



PEOPLE



AMBITION



SYNERGY



MAS GmbH
Schmigalla Str. 1
71229 Leonberg
Germany
Tel. +49 7152-6065-0
Fax +49 7152-6065-65
zentrale@mas-tools.de
www.mas-tools.de

MAS US Inc.
11 Freedom Ct.
Greer, SC 29650
USA
Phone +(864) 365-9583
office@mastools.com
www.mastools.com