

## VARIO<sup>®</sup>turn Hardfacts

- **400% higher part output** thanks to special high-feed geometry
- Roughing and finishing with the same tool, resulting in optimum coordination between cutting material and tool geometry
- **Multifunctional:** facing, diameter machining, radii, bevels - holistic tool concept enables versatile use
- **85% reduction in processing time**

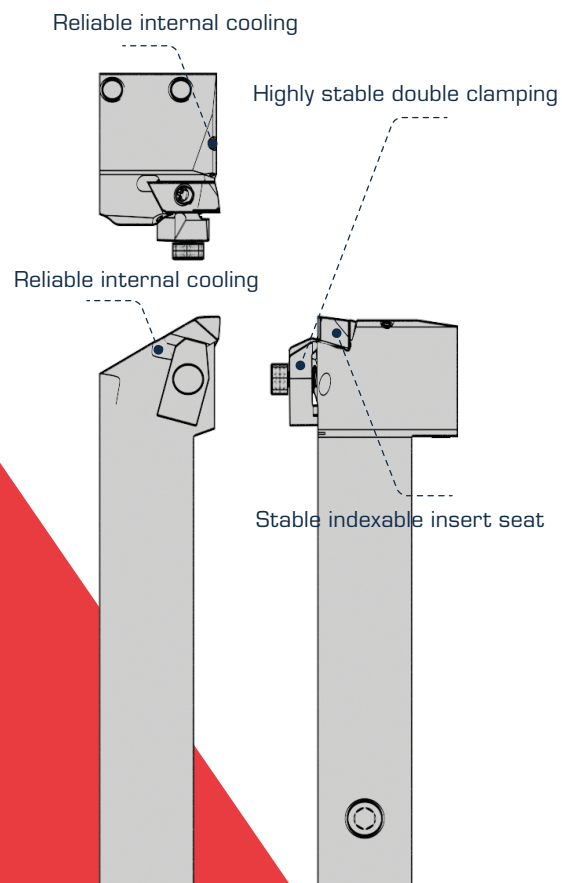

## VARIO<sup>®</sup>turn CBN High Feed Tool





## VARIO<sup>®</sup>turn

- Multifunctional: Highly productive roughing and finishing with one tool
- 85% reduction in processing time
- Holistic tool concept enables versatile use
- Perfect for interrupted cuts and maximum cutting depths